

CENTRIFUGAL PUMP

Centrifugal Pumps are suitable for both domestic and industrial applications to convey clean liquids and non-aggressive chemical fluids. These pumps are characterized by low head and high capacity.

50Hz - Technical parameter

Model	Voltage	Frequency	Power P2		Current	Rated head	Rated flow	DNA	DNM	G.W
	V	Hz	kW	HP	amp	m	m ³ /h	inch	inch	kg
DWK025(T)	220	50	0.25	0.35	2.0	9	2.4	G 1 1/4	G 1	6.3
DWK037(T)	220	50	0.37	0.5	2.4	9	3.6	G 1 1/4	G 1	6.5
DWK50(T)	220	50	0.37	0.5	2.4	6.5	4.8	G 1 1/4	G 1	6.5

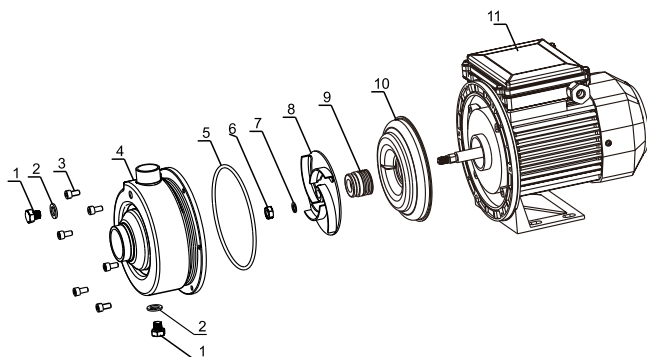
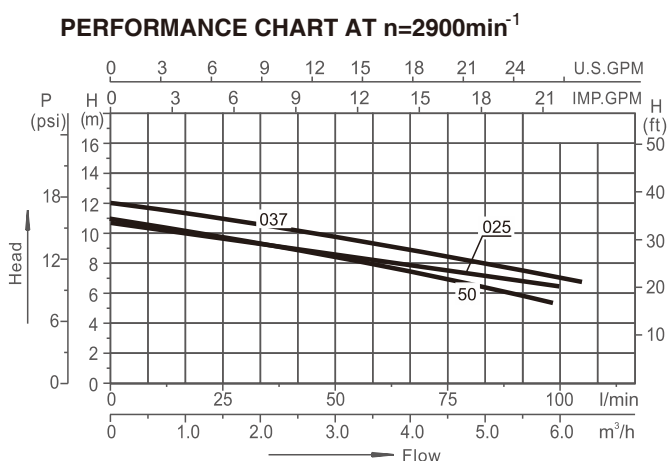

EXPLODED VIEW DRAWING - SPARE PARTS

No.	Description.	No.	Description
1	Plug	7	Spring washer
2	Washer	8	Impeller
3	Inside hexagonal bolt	9	Mechanical seal
4	Pump housing component	10	Pump Cover
5	O-Ring	11	Motor
6	Hexagonal Nut		

available also in 60Hz