

CENTRIFUGAL PUMP

Centrifugal Pumps are suitable for both domestic and industrial applications to convey clean liquids and non-aggressive chemical fluids. These pumps are characterized by low head and high capacity.

60Hz - Technical parameter

Model	Voltage	Frequency	Power P2		Current	Rated head	Rated flow	DNA	DNM	Curves
			kW	HP	Amp	m	m³/h			
DWK100A(T)	220V	60HZ	0.55	0.75	4	7.00	12.00	G1 1/2"	G1 1/2"	1
DWK100(T)	220V	60HZ	0.75	1.00	5	7.00	12.00	G1 1/2"	G1 1/2"	1
DWK120A(T)	220V	60HZ	0.75	1.00	5	10.00	12.00	G1 1/2"	G1 1/2"	2
DWK120(T)	220V	60HZ	1.00	1.40	6	10.00	12.00	G1 1/2"	G1 1/2"	2
DWK150(T)	220V	60HZ	1.10	1.50	7	7.80	18.00	G2"	G2"	3
DWK200(T)	220V	60HZ	1.50	2.00	9	10.50	18.00	G2"	G2"	4
DWK300(T)	220V	60HZ	2.20	3.00	14	11.00	30.00	G2 1/2"	G2"	5

PERFORMANCE CHART AT $n=3450\text{min}^{-1}$

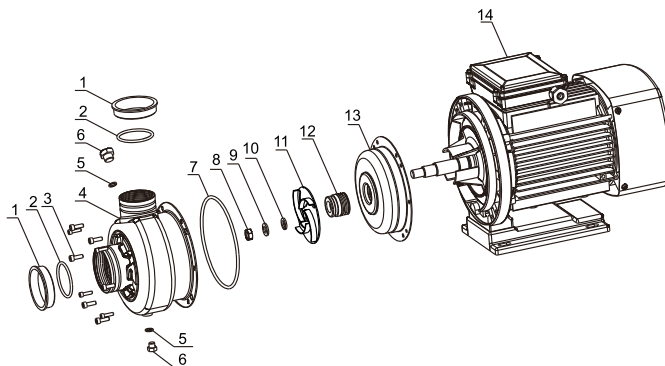
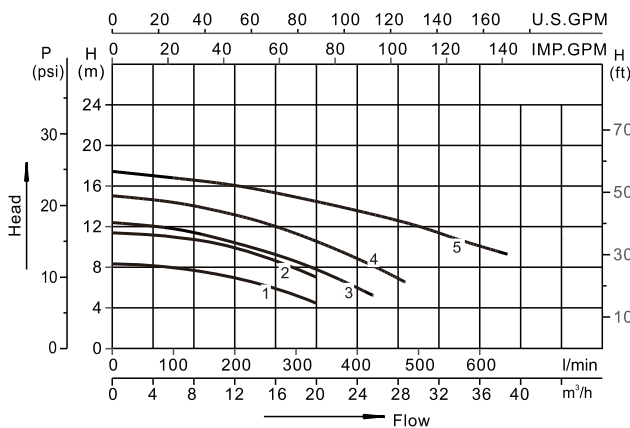

EXPLODED VIEW DRAWING - SPARE PARTS

No.	Description.	No.	Description
1	Dust cap	8	Hexagonal Nut
2	O-Ring	9	Washer
3	Inside hexagonal bolt	10	Spring washer
4	Pump housing component	11	Impeller
5	O-Ring	12	Mechanical seal
6	Plug	13	Pump Cover
7	O-Ring	14	Motor

available also in 50Hz