

CENTRIFUGAL PUMP

Centrifugal Pumps are suitable for both domestic and industrial applications to convey clean liquids and non-aggressive chemical fluids. These pumps are characterized by low head and high capacity.

50Hz - Technical parameter

Model	Voltage	Frequency	Power P2		Current	Rated head	Rated flow	DNA	DNM	G.W	Curves
	V	Hz	kW	HP	amp	m	m ³ /h	inch	inch	kg	
DWK100A(T)	220	50	0.55	0.75	3.8	7	12	G1 1/2	G1 1/2	8.8	1
DWK100(T)	220	50	0.75	1	5.2	7	12	G1 1/2	G1 1/2	9.8	1
DWK120A(T)	220	50	0.75	1	5.2	10	12	G1 1/2	G1 1/2	9.8	2
DWK120(T)	220	50	1	1.4	6.2	10	12	G1 1/2	G1 1/2	10.7	2
DWK150(T)	220	50	1.1	1.5	7	7.8	18	G2	G2	15.5	3
DWK200(T)	220	50	1.5	2	9.2	10.5	18	G2	G2	17.5	4
DWK300(T)	220	50	2.2	3	14	11	30	G2 1/2	G2	21.5	5
DWK400(T)	220	50	3	3.3		15	30	G2 1/2	G2	23.1	6

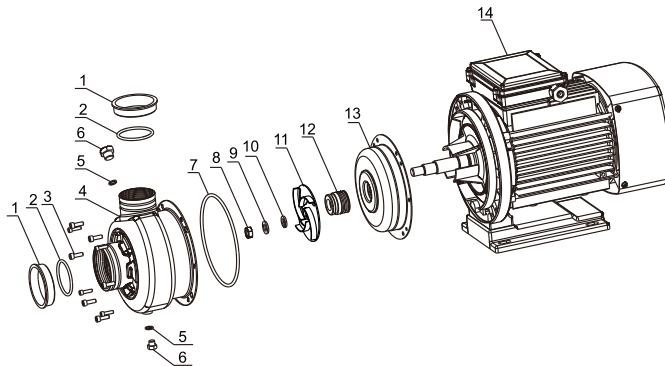
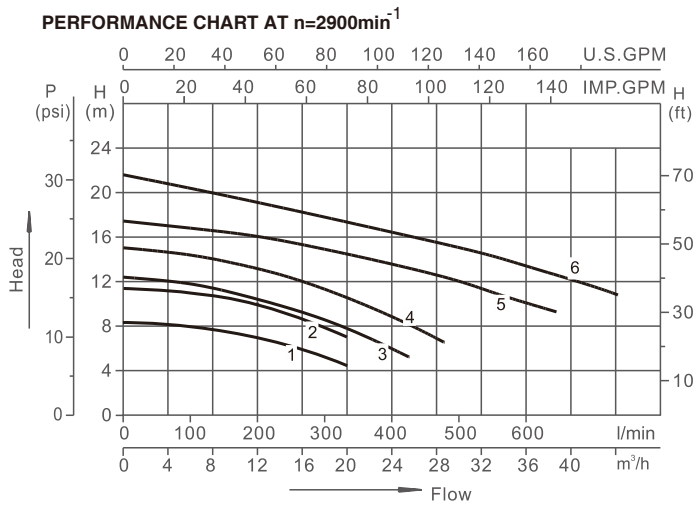

EXPLODED VIEW DRAWING - SPARE PARTS

No.	Description.	No.	Description
1	Dust cap	8	Hexagonal Nut
2	O-Ring	9	Washer
3	Inside hexagonal bolt	10	Spring washer
4	Pump housing component	11	Impeller
5	O-Ring	12	Mechanical seal
6	Plug	13	Pump Cover
7	O-Ring	14	Motor

available also in 60Hz