

# CENTRIFUGAL PUMP

**Centrifugal Pumps** are suitable for both domestic and industrial applications to convey clean liquids and non-aggressive chemical fluids. These pumps are characterized by low head and high capacity.

## 50Hz - Technical parameter

Model	Voltage	Frequency	Power		Current	H.Max	Q.Max	Size	S.Head	G.W
	V	Hz	kW	HP	amp	m	L/min	inch	m	kg
HFM/1B	220	50	0.6	0.8	3.5	16	275	G1.5" x G1.5"	8	12.5
HFM/1A	220	50	0.75	1	5.5	20	275	G1.5" x G1.5"	8	13.5
HFM/5C	220	50	0.6	0.8	3.5	12.5	500	G2" x G2"	8	14.8
HFM/5B	220	50	0.75	1	5.5	14	600	G2" x G2"	8	15.7
HFM/5A	220	50	1.1	1.5	7.5	15	650	G2" x G2"	8	16.3
HFM/6C	220	50	1.1	1.5	7.5	12	1100	G3" x G3"	8	28.6
HFM/6B	220	50	1.5	2	8.5	15	1200	G3" x G3"	8	29.8
HFM/6A	220	50	2.2	3	12	19	1300	G3" x G3"	8	39.6
HFM/7B	220	50	3	4	14	22	1300	G3" x G3"	8	41

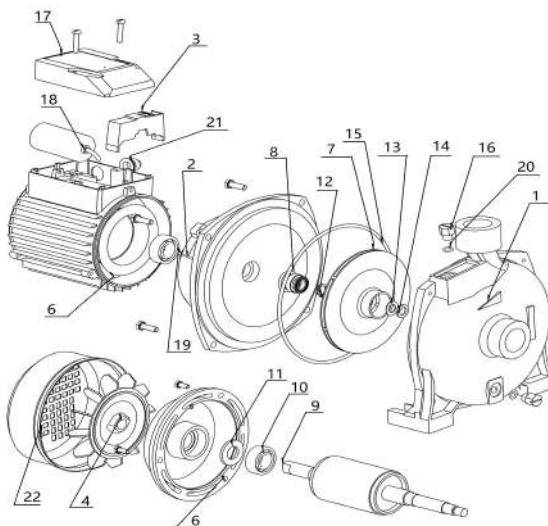
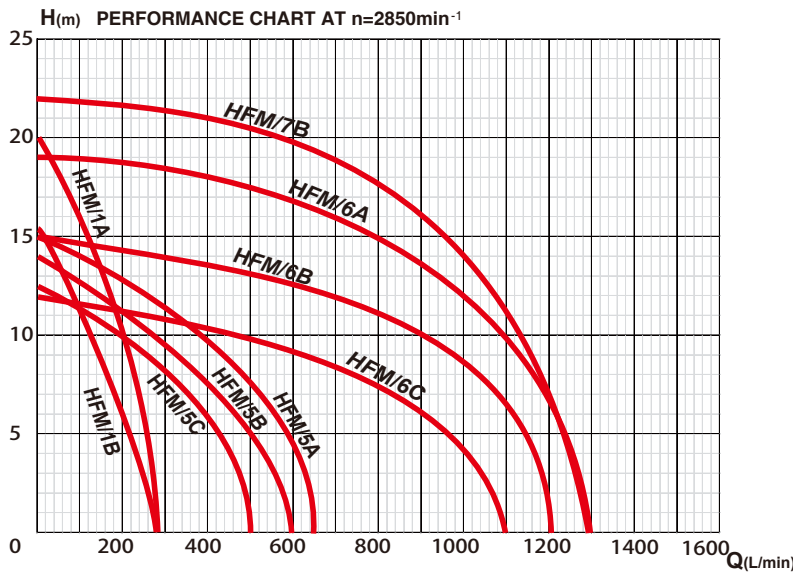

### EXPLODED VIEW DRAWING - SPARE PARTS

No.	Description.	No.	Description
1	Pump Body	15	O ring
2	Motor Front cover	16	Flit plug screw
3	Terminal block	17	Terminal cover
4	Fan	18	Capacitor
5	Motor end cover	19	Washer
6	Motor body	20	O ring
7	Impeller	21	Fairlead
8	Mechanical seal	22	Fan cover
9	Motor rotor		
10	Ball bearing		
11	Spring washer		
12	Locking ring		
13	Washer		
14	Washer		

available also in 60Hz