

# SELF-PRIMING PUMP

**Self-priming Pumps** are equipped with aVenturi system.They are suitable to convey clean water and non-aggressive chemical fluids, even with liquid mixed with gas, from well in continuous duty; they are also indicated to increase water pressure in centralized water systems, for small irrigation systems, for watering gardens, for washing systems with water jets, for fountains, etc. It is normally advisable to install a foot valve on the suction end.

## 50Hz - Technical parameter

Model	Voltage	Frequency	Power		Current	H.Max	Q.Max	Size	S.Head	G.W
	V	Hz	kW	HP	amp	m	L/min	inch	m	kg
JET60S	220	50	0.37	0.5	2.9	35	40	G1" x G1"	9	10
JET80S	220	50	0.55	0.75	3.5	44	50	G1" x G1"	9	11
JET100S	220	50	0.75	1	5.5	48	60	G1" x G1"	9	12

H(m) PERFORMANCE CHART AT n=2850min<sup>-1</sup>

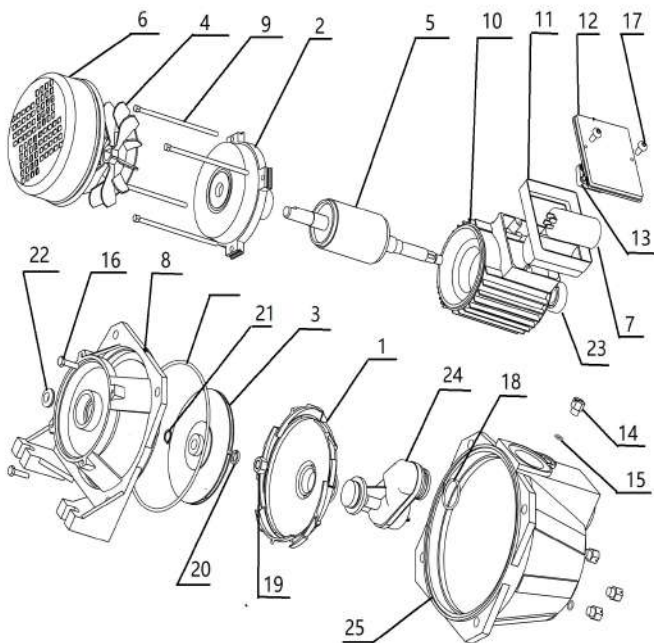
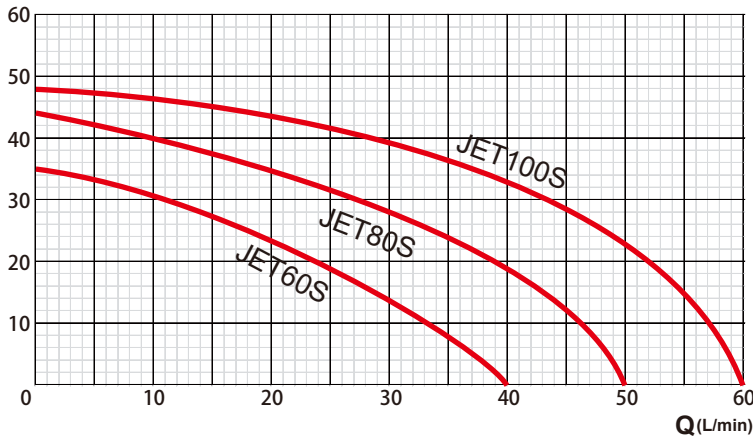

**EXPLODED VIEW DRAWING - SPARE PARTS**

No.	Description.	No.	Description.
1	Fluidic device	18	O ring
2	Motor end cover	19	Nut
3	Impeller	20	Spring washer
4	Fan	21	Locking ring
5	Motor rotor	22	Washer
6	Fan cover	23	Ball bearing
7	Capacitor	24	Venturi
8	Motor front cover	25	Pump body
9	Screw		
10	Motor body		
11	Terminal box		
12	Terminal cover		
13	Terminal block		
14	Flit plug screw		
15	O ring		
16	Screw		
17	Screw		

available also in 60Hz