

SELF-PRIMING PUMP

Self-priming Pumps are equipped with a Venturi system. They are suitable to convey clean water and non-aggressive chemical fluids, even with liquid mixed with gas, from well in continuous duty; they are also indicated to increase water pressure in centralized water systems, for small irrigation systems, for watering gardens, for washing systems with water jets, for fountains, etc. It is normally advisable to install a foot valve on the suction end.

50Hz - Technical parameter

Model	Voltage	Frequency	Power		Current	H.Max	Q.Max	Size	S.Head	G.W
	V	Hz	kW	HP	amp	m	L/min	inch	m	kg
JS60	220	50	0.37	0.5	2.9	35	38	G1" x G1"	9	6.8
JS80	220	50	0.55	0.75	3.5	40	43	G1" x G1"	9	7.2
JS100	220	50	0.75	1	5.5	45	49	G1" x G1"	9	7.6

H(m) PERFORMANCE CHART AT n=2850min⁻¹

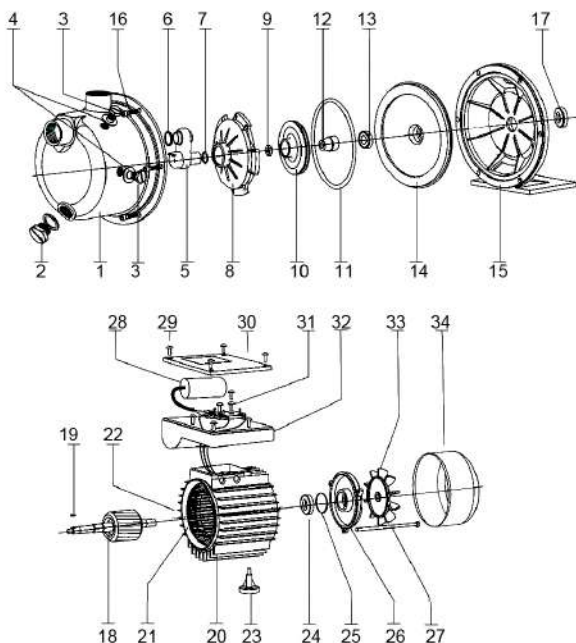
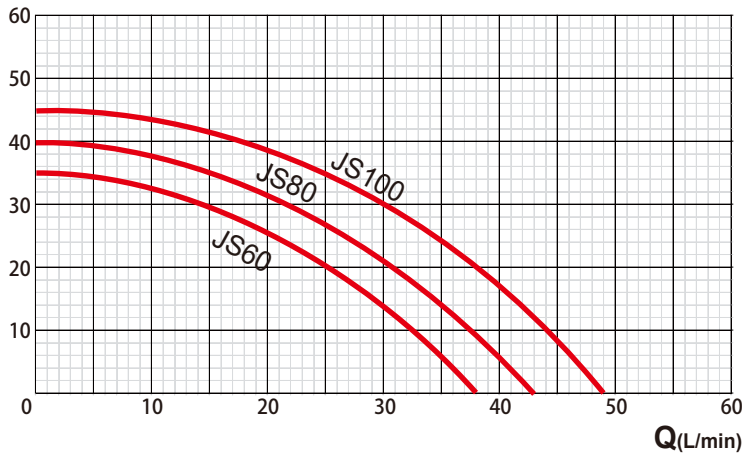

EXPLODED VIEW DRAWING - SPARE PARTS

No.	Description.	No.	Description.
1	Pump Body	18	Motor Rotor
2	Coper Screw	19	Shaft Key
3	Flit Plug Screw	20	Motor Body
4	Seal	21	Stator
5	Fluidic Device	22	Stator Coil
6	Jet Seal	23	Motor Foot
7	Jet Seal	24	Ball Bearing
8	Propelling Sheave	25	Spring Washer
9	Locking Nut	26	Motor End Cover
10	Impeller	27	Bolt
11	O Ring	28	Capacitor
12	Mechanical Seal	29	Terminal Box Screw
13	Mechanical Seal	30	Terminal Cover
14	Pump Cover Board	31	Screw
15	Motor Front Cover	32	Terminal Box
16	Screw	33	Fan
17	Ball Bearing	34	Fan cover

available also in 60Hz