

AIR COOLED DIESEL ENGINE

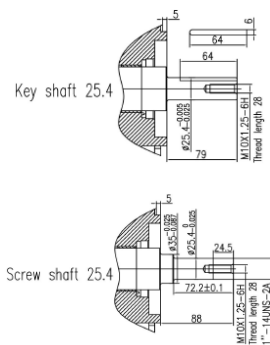

NK2V95F

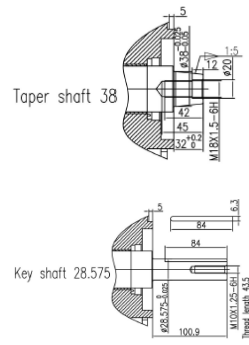
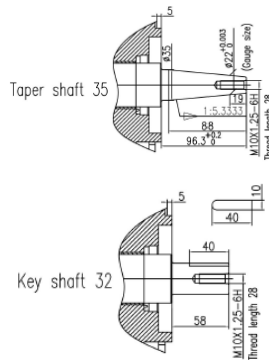
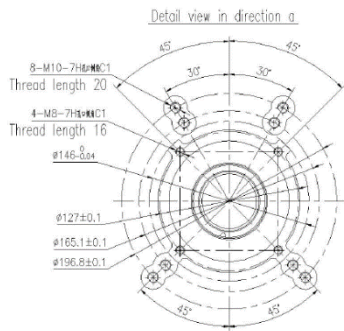

Model		NK2V95F
Engine type		V-twin, 4 stroke, air cooled
Bore*stroke	mm	95*88
Displacement	cc	1247
Rotation Speed	rpm	3000/3600
Rated Output Power	kW	19/20
Max. Output Power	HP	27/28
Fuel Consumption	gr/Kw*h	250/265
Starting System		Electric
Overall Dimension	mm	630*550*730
Net Weight	Kg	82

NK2V95F

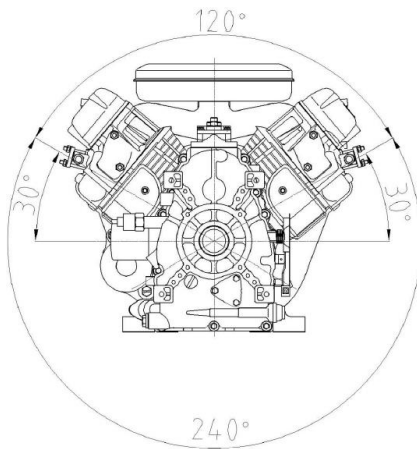
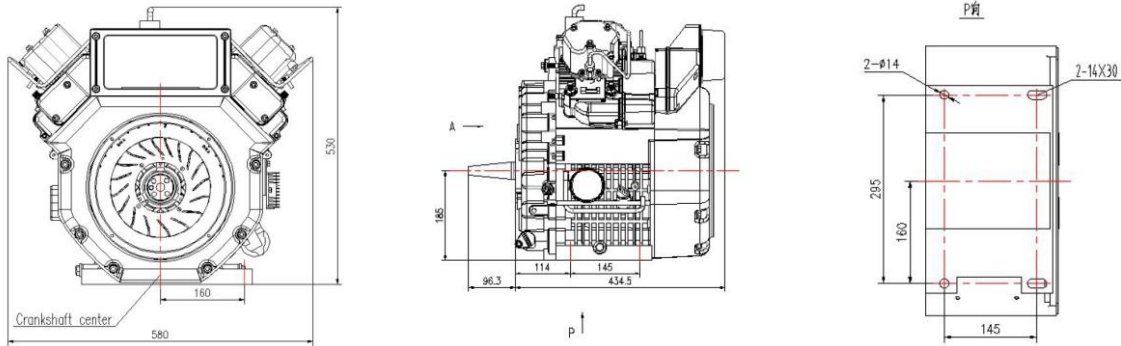

Output end Gradient		
Permit Gradient (continuum running)	<20°	
Engine Gradient		
Permit Gradient (continuum running)	<20°	

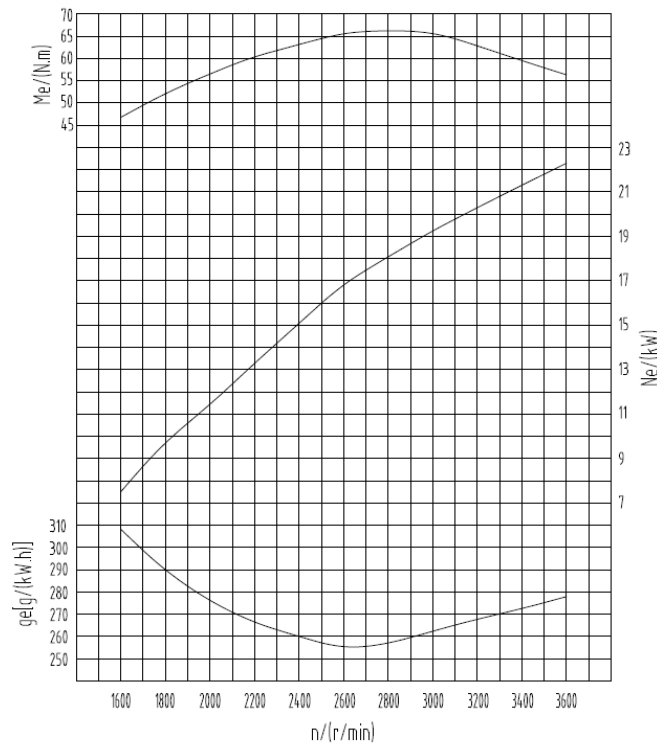

2V95外特性曲线